

The Calibration System Based On the Controllable UV/visible LED Flasher for the Veto System of the DarkSide Detector

This content has been downloaded from IOPscience. Please scroll down to see the full text.

2017 J. Phys.: Conf. Ser. 798 012118

(<http://iopscience.iop.org/1742-6596/798/1/012118>)

View [the table of contents for this issue](#), or go to the [journal homepage](#) for more

Download details:

IP Address: 213.131.7.131

This content was downloaded on 24/03/2017 at 11:30

Please note that [terms and conditions apply](#).

You may also be interested in:

[Dark Matter in the Universe: Direct detection of dark matter](#)

M S Seigar

[The electronics and data acquisition system for the DarkSide-50 veto detectors](#)

P. Agnes, L. Agostino, I.F.M. Albuquerque et al.

[Supernova Registration in Water Cherenkov Veto of Dark Matter Detectors](#)

E A Litvinovich, I N Machulin, D A Pugachev et al.

[The veto system of the DarkSide-50 experiment](#)

P. Agnes, L. Agostino, I.F.M. Albuquerque et al.

[Automated Calibration System for Lead Glass Counters](#)

Masatosi Imori, Tomio Kobayashi and Hiroshi Takeda

[Calibration system of the LHCb hadronic calorimeter](#)

D Yu Pereima, D Yu Golubkov, Yu P Guz et al.

[Technique to measure the cosmic muon flux at the old Canfranc Underground Laboratory](#)

A Rodríguez, J M Carmona, S Cebrián et al.

[Performance data from the ZEPLIN-III second science run](#)

P Majewski, V N Solovov, D Yu Akimov et al.

[The XENON100 dark matter experiment at LNGS: Status and sensitivity](#)

Elena Aprile and the Xenon Collaboration

The Calibration System Based On the Controllable UV/visible LED Flasher for the Veto System of the DarkSide Detector

A S Chepurnov¹, M B Gromov^{1,2,6}, E A Litvinovich^{3,4},
I N Machulin^{3,4}, M D Skorokhvatov^{3,4} and A F Shamarin⁵

¹Lomonosov Moscow State University, Skobeltsyn Institute of Nuclear Physics,
119234 Moscow, Russia

²Lomonosov Moscow State University, Faculty of Physics, 119234 Moscow, Russia

³NRC "Kurchatov Institute", 123182, Moscow, Russia

⁴National Research Nuclear University MEPhI (Moscow Engineering Physics Institute),
Kashirskoe highway 31, Moscow, 115409, Russia

⁵OOO Marathon, 119234 Moscow, Russia

E-mail: gromov@physics.msu.ru, aschepurnov@gmail.com

Abstract. A prototype of the calibration system for the Liquid Scintillator Veto (LSV) and for the Water Cherenkov Veto (WCV) of the DarkSide detector have been developed. The instrument consists of a fast double output flasher which can be configured and controlled via USB, the appropriate application software. UV, visible or combination of both LEDs could be installed. Flashes amplitude, repetition rate and delay time between two continuous pulses are adjustable. High -OH silica fibers are used to minimize intensity losses on the delivery path. X shape splitter is used to combine two LED's pigtailed output and then to split the sum of the signals. One output feeds calibration path to the detector, while the second is used for pulse-to-pulse measurement of the flash intensity with compatible photodiode in combination with Flash ADC. The instrument allows to simulate point-like physical events in very wide energy range from a few hundred keV up to several dozen of MeV. Additional studies (pile-up analysis, spatial reconstruction, quenching as a function of position and wavelength) can be performed due to double-LEDs scheme and possibility of fast replacement of diodes.

1. Introduction

The new generation of detectors for direct search of dark matter WIMP (Weakly Interacting Massive Particles) is under construction in main underground laboratories all over the world. The main feature of the future detectors to detect WIMPs should be multi-ton volume of the target together with ultra low self-radioactivity. Single and double phase liquid noble gases detectors are considered as promising types to achieve such large target size. For example, the DS-20k detector will use more than 20 tons of liquid depleted argon in time projection chamber (TPC) as WIMPs trap [1]. But the main demand of the low background experiments focused on shielding against external and internal backgrounds sources implies a concentric onion-like construction. The DS-20k detector will have the Liquid Scintillator spherical Veto (LSV) surrounding TPC

⁶ To whom any correspondence should be addressed.



and the cylindrical water tank playing role of Water Cherenkov Veto (WCV) surrounding LSV. Both veto volumes must be tested and calibrated in very wide energy range from about 50 keV up to few hundreds of MeV. Also the calibration procedure should provide information for spatial reconstruction algorithms that requires simulation of the point-like events at the predefined positions. A standard methods applying radioactive sources provides the possibility to calibrate the detectors below 11–12 MeV (for example, [2]). Offline techniques (cosmogenic ^{12}B decay, michel electron spectrum and etc) allow to overcome this constraint but such ways are limited by a number of energy reference points and lack of information for spatial reconstruction. Therefore an additional new calibration system is strongly required and the respective device called the controllable ultraviolet(UV)/visible LED flasher is proposed in this article.

2. Historical overview

The main difficulty when creating calibration systems based on LED as nanosecond photon flashes source was the design of a circuitry of a nanosecond LED driver. It has been successfully accomplished by J. S. Kapustinsky and his colleagues [3] in 1985. This circuit diagram was named "Kapustinsky's" light pulser and it became quite popular [4, 5]. Next step was upgrading the scheme for using with UV and blue LEDs in 2004–2006 [6]. The stability of the "Kapustinsky's" light pulser was carefully studied [7] as well. Different improvements of the scheme were also proposed [8]. The circuitry was successfully implemented in the TUNKA [9] and GERDA [10] experiments. Nevertheless the first working prototype with digitally controllable parameters of the pulse via USB from PC for online calibration of neutrino liquid scintillator detectors at energies above 10 MeV was presented at the ICPPA-2015 conference [11]. In this article it is reported that some measurements have been made to demonstrate the feasibility and capability of the system. Also several other prototypes for multipurpose calibration campaigns and testing of the experimental equipment have been developed.

3. General description

The original goal of the R&D is to obtain the system for calibration of neutrino and dark matter detectors and for simulation any physical signals. If the former is quite understandable (calibration itself, relatively low energy error, accurate background measurement and etc), the latter should be commented. At the present time modeling is performed with Monte Carlo simulators. It implies the necessity to develop special software packages that not only include the digital replica of the detector itself, but the electronics as well. In most cases it is difficult to do that in a proper manner. In consequence the additional systematic error has arisen. The issue can be solved with the controllable LED flasher which is able to generate any given sequence of pulses imitating the real physical events. For example, it makes sense to mention cosmogenic isotope decays, geo-neutrinos, dark matter interactions with media, supernova signals and radioactive sources for sterile neutrino search.

The proposed system is based on an assumption that the energy of the simulated signal is directly proportional to the number of emitted photons. The conception of the device has five foundations. Here they are. 1) Adjustable level of the output power of the LED flashers. 2) Double-LEDs scheme. 3) Pulse to pulse monitoring of the flasher output. 4) All components except the end of the fiber with diffuser can be placed outside a cleanroom. 5) To increase the the isotropy of the UV radiation the diffuser is mounted at the edge of the fiber inside the detector. The details can be found in the previous paper [11].

The basic scheme and the photograph of the controllable UV/visible LED flasher are shown on figures 1 and 2. The properties of generated pulses is controlled with a PC program via USB interface. The Double-LEDs scheme can operate in two regimes. The first one provides two signals with some delay. The second mode is aimed to increase the power of flashes or in other words the deposited energy. In this case the delay is zero and two signals are simply summed

in one. If the power of the signal is insufficient, more than two LEDs or an array of LEDs in a single housing will be able to be applied. But this approach is required a splitter with another shape and probably new pigtail solutions for LEDs/arrays of LEDs.

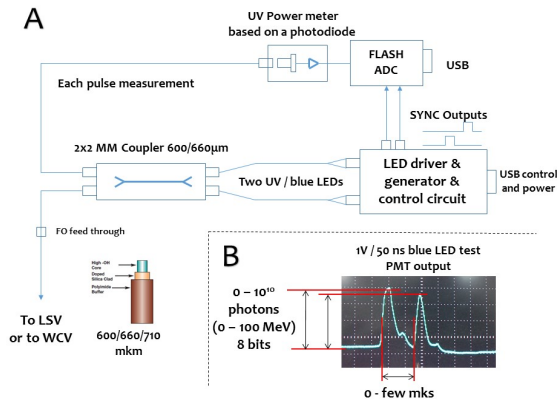

Figure 1. The general scheme. A) The basic simplified scheme of the LED calibration system for LSV and WCV. B) An example of generated signals with ranges of parameters.

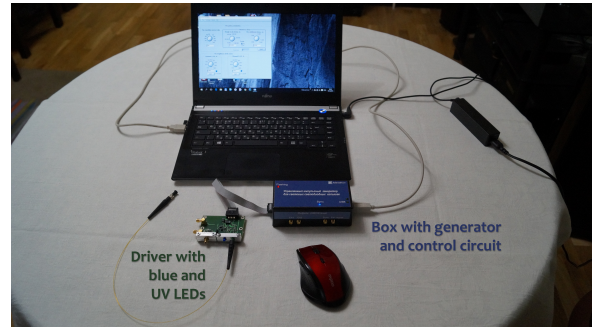

Figure 2. The version of the system with blue and UV LEDs. Also the PC with the corresponding software application window is shown.

4. Demonstration measurements

In order to test all components and to demonstrate the feasibility and capability of the system the simple experimental setup was assembled. It is shown on figure 3. The UV pulses are registered by MELZ PMT-85 [12] in a vial with 50 ml a sample of the liquid organic scintillator (LAB + 3 g/l PPO + 0.03 g/l POPOP + 3 g/l Gd(TMHA)₃) applied in the iDREAM experiment as one of the possible options [13]. The deposited energy depends on the applied voltage at the diode. In the current version of the flasher the voltage is adjusted discretely with a minimal step of 0.4% of the maximum voltage. The current setup and input range $2 V_{pp}$ of the ADC (CAEN DT5730) allow to measure only four pulses with different amplitudes. Their spectra are displayed on figure 4. The diode begins to flash at $\sim 34.5\%$ of the maximum voltage but the first pulse sinks in dark noises of the PMT. Those noises are cut on figure 4. Other residual backgrounds are negligible. All spectra were fitted with the Gaussian function. The nonlinear pulse amplitude dependence of the applied voltage has been observed.

5. Conclusion

The new non-radioactive calibration system is proposed for the DarkSide detector in order to construct the energy scale up to about 100 MeV in LSV and WCV as a function of source position. Further development of the ideas that are put forward will be undertaken in three directions. The first one is further testing and implementation the devices in the detectors. It is planned to use the systems in the iDREAM [13], Borexino [14], Double Chooz [15] and JUNO [16] experiments. The second direction is development of a set of the plugins for simulation given sequence of pulses imitating the real physical phenomena. And the last direction is the design of new systems based on the existing platform according to requests.

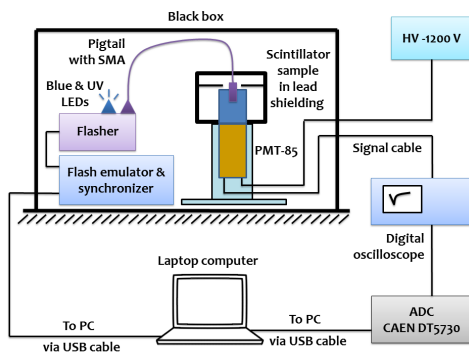

Figure 3. The experimental setup

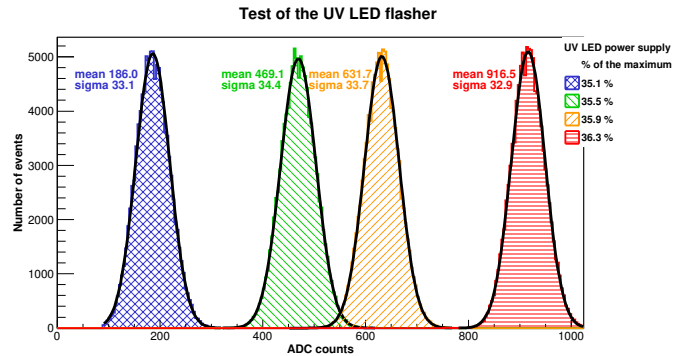

Figure 4. The spectra of the UV pulses at four different voltages. 600 ADC counts roughly correspond to 1 MeV.

Acknowledgments

The research was supported by the grant of the Russian Science Foundation (project №16-12-10369). The authors are grateful to G. A. Lukyanchenko, A. Y. Oralbayev and D. S. Marcov for help in studies and useful discussions.

References

- [1] Aalseth C E *et al.* (DarkSide Collaboration) 2015 *Advances in High Energy Physics* **7**(3) 541362
 URL Journal website
- [2] Back H *et al.* (Borexino Collaboration) 2012 *JINST* **7** P10018 URL IOP website (*Preprint 1207.4816v2*)
- [3] Kapustinsky J S *et al.* 1985 *Nucl. Instrum. Meth. A* **241**(2–3) 612–13 URL ScienceDirect website
- [4] Belolaptikov I A *et al.* 1997 *Astropart. Phys.* **7**(3) 263–82 URL ScienceDirect website
- [5] McMillan J E *et al.* 2001 *Proc. 27th Int. Cosmic Ray Conf. (August 7–15, Hamburg)* vol 1 (HE part 2) (Göttingen: Copernicus Gesellschaft) p 1287 URL 27th ICRC website
- [6] Lubsandorzhev B K and Vyatchin Y E 2006 *JINST* **1** T06001 URL IOP website (*Preprint physics/0410281v1*)
- [7] Lubsandorzhev B K and Vyatchin Y E 2004 Stability studies of nanosecond light sources based on blue ultra bright leds *Preprint physics/0403018v1*
- [8] Veledar O *et al.* 2007 *Meas. Sci. Technol.* **18**(1) 131–37 URL IOP website
- [9] Lubsandorzhev B K *et al.* 2007 *Proc. 30th Int. Cosmic Ray Conf. (July 3–11, Mérida)* vol 5 (HE part 2) ed Caballero R *et al.* (Mexico City: Universidad Nacional Autónoma de México) pp 1117–20
 URL 30th ICRC website (*Preprint 0709.0458v1*)
- [10] Ritter F *et al.* 2009 *Nucl. Instrum. Meth. A* **617**(1–3) 420–21 URL ScienceDirect website
 (*Proceedings of the 11th Pisa Meeting on Advanced Detectors*)
- [11] Chepurnov A S, Gromov M B and Shamarin A F 2016 *J. Phys.: Conf. Series* vol 675 p 012008
 URL IOP website
- [12] «MELZ FEU», Ltd. URL MELZ FEU website
- [13] Gromov M B *et al.* 2015 *Moscow University Physics Bulletin* **70**(3) 190 URL Journal website (original Russian text: *Vestnik Moskovskogo Universiteta. Seriya 3. Fizika i Astronomiya* 2015(3) 26)
- [14] Alimonti G *et al.* (Borexino Collaboration) 2009 *Nucl. Instrum. Meth. A* **600**(3) 568–93 URL ScienceDirect website (*Preprint arXiv:0806.2400v1*)
- [15] Cabrera A (Double Chooz Collaboration) 2010 *Nucl. Instrum. Meth. A* **617**(1–3) 473–77
 URL ScienceDirect website
- [16] An F *et al.* (JUNO Collaboration) 2016 *J. Phys. G* **43**(3) 030401 URL IOP website (*Preprint 1507.05613v2*)