

PAPER • OPEN ACCESS

Hydrothermal liquefaction of microalgae for biofuel production: the recycling of nutrients from an aqueous solution after HTL

To cite this article: N I Chernova *et al* 2019 *IOP Conf. Ser.: Mater. Sci. Eng.* **564** 012112

View the [article online](#) for updates and enhancements.

Hydrothermal liquefaction of microalgae for biofuel production: the recycling of nutrients from an aqueous solution after HTL

N I Chernova^{1,2}, S V Kiseleva^{1,2,*}, M S Vlaskin², A V Grigorenko² and Y Y Rafikova¹

¹ Lomonosov Moscow State University, Leninskie Gory, 1, Moscow, Russia

² Joint Institute for High Temperatures of Russian Academy of Science, Izhorskaya st., 13 Bd.2, Moscow, Russia

Email: k_sophia_v@mail.ru

Abstract. Microalgae are an alternative source for the renewable biofuels production. One of the promising technologies of microalgae fuel production is the hydrothermal liquefaction (HTL) with obtaining bio-oil as the target product. We have carried out a number of experiments on the hydrothermal liquefaction the biomass of blue-green microalgae *Arthrospira platensis rsemsu 1/02-P* (collection of Renewable Source Energy Laboratory at Lomonosov Moscow State University). For the HTL of arthrospira biomass the reactor of the Institute of High Temperatures RAS have been used. The outputs of bio-oil, gaseous products, solid residue and aqueous solution were 34-46%, 12-18%, 26-30%, 10-24% respectively. The aqueous solution hydrothermal liquefaction is a by-product, it has a limited energy value and needs to be recycled. Aqueous solution contains the nutrients necessary for growing algae but in quantities that are orders of magnitude higher than the standard ones. Studies growth of different algae species in aqueous solution after HTL have shown that in order to prevent the growth inhibitors toxic effect intensive its dilution is necessary. Microalgae strains, which can be cultivated in 500-fold diluted aqueous solution (*Galdieria sulphuraria rsemsu G-1*, *Chlorella vulgaris rsemsu Chv-20/11-Ps*), have been experimentally selected. It allows partially recycling the by-product of bio-oil from microalgae

1. Introduction

The growth of the consumption of energy and the increasing environmental pollution pose serious problems for the further development of society. Bioenergy is a clean alternative (renewable) energy source that can be used in order to both solve energy problems and improve the environmental situation. However, for the development of bioenergy, a new renewable non-food sources of feedstock are needed. Such sources should be easily processed into the usable forms of energy carriers. One of such sources of feedstock is the microalgae (MA) biomass. Unlike widely used energy crops, microalgae show a significant advantage as energy feedstock: higher photosynthetic efficiency and productivity, ability to grow on wastewater and lack of competition for arable land [1]. Microalgae biomass can be transformed into biofuel using hydrothermal liquefaction, pyrolysis, gasification, and anaerobic digestion [2, 3]. Algae can be used to produce hydrogen also [4, 5].

Microalgae fuel is a third-generation biofuel. One of the promising technologies of microalgae to biofuel conversion is the hydrothermal liquefaction (HTL) with the production of bio-oil as the target



product [6, 7]. However, in the process of HTL, an aqueous solution (AS) is formed as a by-product, which has limited energy value and needs to be recycled [8-12]. The aim of this study is to study the possibility of utilization of the nutrients from an aqueous solution produced after HTL.

2. Materials and methods

The clone culture of blue-green microalgae / cyanobacteria *Arthrospira platensis rsemsu 1/02-P* strain with straight trichomes formed due to natural morphological variability during long-term cultivation under laboratory conditions was used as a feedstock for HTL [5]. Biomass was obtained by semi-continuous cultivation in open pond with volume of 1000 L and illumination of $55 \pm 5 \mu\text{E}/(\text{m}^2 \times \text{s})$ at steady-lighting conditions and temperature of 21 °C. *A. platensis* was cultivated using Zarrouk's medium: $\text{NaHCO}_3 - 16.8 \text{ g/l}$, $\text{KNO}_3 - 3.0 \text{ g/l}$, $\text{K}_2\text{HPO}_4 \cdot 3\text{H}_2\text{O} - 0.66 \text{ g/l}$, $\text{K}_2\text{SO}_4 - 1.0 \text{ g/l}$, $\text{MgSO}_4 \cdot 7\text{H}_2\text{O} - 0.2 \text{ g/l}$, $\text{NaCl} - 1.0 \text{ g/l}$, $\text{CaCl}_2 - 0.04 \text{ g/l}$, $\text{FeSO}_4 \cdot 7\text{H}_2\text{O} - 0.018 \text{ g/l}$, EDTA – 0.08 g/l, Zarrouk's trace metal solution – 1.0 ml/l, (per 1 l of distilled water). The elemental composition of *A. platensis* (Table 1) was determined on the analyzer VARIO EL III Elementar Analyzer systeme GmbH, the biochemical composition (the determination of proteins, lipids and carbohydrates) was carried out according to known methods [13-15].

Table 1. Characteristics of the *Arthrospira platensis rsemsu 1/02-P*: elemental composition (dry ash free state, the oxygen content was determined by subtraction), ash content, humidity, biochemical composition (wt%).

| Elemental composition | | | | | Ash content | Humidity | Biochemical composition | | |
|-----------------------|-----|------|-----|------|-------------|----------|-------------------------|--------|---------------|
| C | H | N | S | O | | | Protein | Lipids | Carbohydrates |
| 49.9 | 7.3 | 11.3 | 4.0 | 27.6 | 6.0 | 3.0 | 60,7 | 12.1 | 7.1 |

Hydrothermal processing experiments were performed at a laboratory reactor shown in Figure 1. The photo of the plant is shown in Figure 2 a, b. The reactor-autoclave, which has a volume of 0.9 L, is designed for 30 MPa and a maximum operating temperature of 500°C. The reactor heating is external ohmic. A PC operator controlled the heating process (heating rate, maximum temperature, and holding time) by an automated control and monitoring system. The temperature inside the reactor was measured with a temperature sensor placed into a special tube (liner) immersed into the reactor.

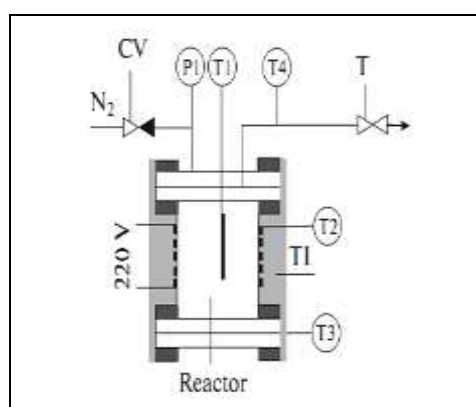

Figure 1. Scheme of the laboratory autoclave type reactor : CV is a check valve, TI is thermal insulation, T is tap, P is pressure sensor, and T1–T4 is thermocouples.

The heating process (heating rate, maximum temperature and exposure time) is controlled by a PC operator using an automated control system (supplied by National Instruments). The reactor was loaded with 500 grams of distilled water and 150 grams of dried microalgae. Then, the reactor was sealed and purged with nitrogen (N₂). Then, the reactor was heated up to a temperature of 270, 300 and 330°C (will be referred to as HTL-270/300/330). After the reactor cooling, the condensed products of hydrothermal liquefaction were removed in a separate container. Condensed products of hydrothermal liquefaction consisted of a mixture of two immiscible liquids and a solid residue (Fig. 2 c). From the bottom, there was an AS in the tank, on top, a dark tar-like liquid with less density (bio-

oil). Bio-oil was separated from the AS mechanically, without using any organic solvents. The solid residue was separated from the AS by filtration on a filter paper. The relative content of the condensed products of HTL-270/300/330 is given in Table 2.

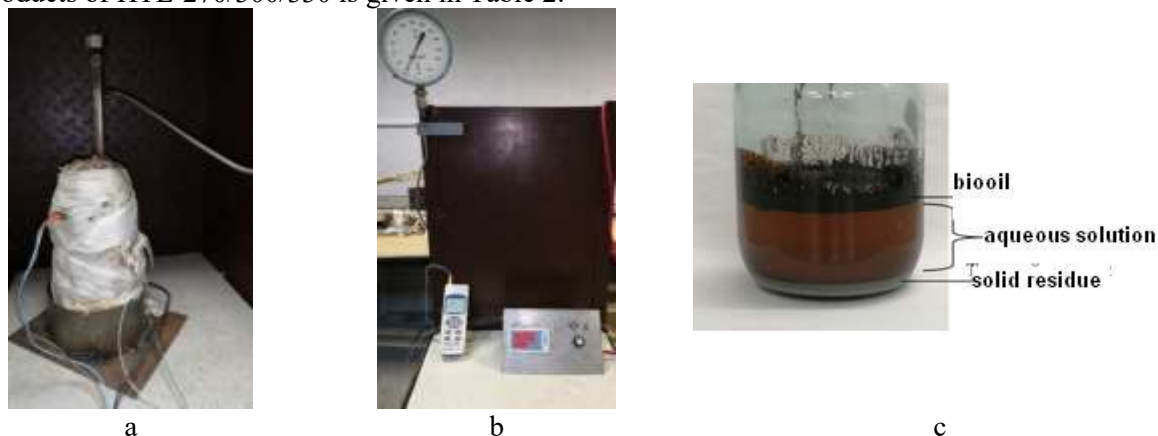

Figure 2. Laboratory stands reactor-autoclave volume 0.9 L (a,b), condensation products of hydrothermal liquefaction of microalgae (c).

Table 2. Product distribution from the hydrothermal liquefaction of *A. platensis rsemsu 1/02-Pat 270*, 300 and 330°C.

| HTL-products, % | Temperature, °C | | |
|------------------|-----------------|------|------|
| | 270 | 300 | 330 |
| Bio-oil/crude | 34,6 | 38,8 | 45,7 |
| Gas | 12,7 | 14,8 | 17,5 |
| Solid Residue | 28,7 | 27,4 | 26,0 |
| Aqueous solution | 24,0 | 19,0 | 10,8 |

The following MA strains were grown on the AS obtained after HTL: *Arthrospira platensis rsemsu 1/02-P*, *A. platensis rsemsu 1/02*, *A. platensis rsemsu 1/02-T*, *Galdieria sulphuraria rsemsu G-1*, *Chlorella vulgaris rsemsu Chv-20/11-Ps* from the collection of Renewable Source Energy Laboratory at LMSU.

3. Results and discussion

The analysis of the composition of the AS obtained in the process of hydrothermal liquefaction of *A. platensis rsemsu 1/02-P* at various temperatures (270, 300 and 330 °C) were carried out. It was found that the AS contains a large amount of nutrients, which are necessary for the MA cultivation, as well as trace elements. (58 compounds were identified). These are biogenic cations: ammonium (14.3 g / l), potassium (4.5 g / l), magnesium (up to 0.05 g / l), sodium (3.8 g / l), calcium (up to 0, 05 g / l), iron (up to 5 mg / l), silicon (20 mg / l); biogenic anions: orthophosphates (5.2 g / l), sulfates (0.53 g / l), nitrates (0.05 g / l), bicarbonates (54.9 g / l), carbonates (7.2 g / l), chlorides (0.6 mg / l), as well as trace elements vital for the growth and development of microalgae: manganese, copper, wolfram, cobalt, chromium, molybdenum, nickel, vanadium, zinc, boron, titanium. Besides mineral elements a large amount of total nitrogen, which contains the ammonium cations (from 14.3 g / l to 23.6 g / l at HTL-270 and 330 respectively), is contained in the AS obtained in HTL. The nitrogen content depends largely on the amount of protein in used biomass. More than a half of the nitrogen from the MA is transferred to the aqueous phase during HTL (it is important to note that *Arthrospira* contains protein of up to 65%). The high content of ammonia formed during protein hydrolysis and deamination, leads to high pH value (8.7-9.2) of ASs obtained at HTL-270 and 330. Organic carbon is presented mainly by short-chain organic acids. A large amount of acetates is also observed (from 11.5

g / l in an AS from HTL-300 to 37.0 g / l - at HTL-270). Acetates can act as a substrate for mixotrophic and heterotrophic growth of some strains of MA, and so they can improve the productivity of MA.

An AS of HTL-270 was most favorable medium for MA cultivation because it had the lowest ammonium concentrations and bicarbonate content (55 g / l), which was more closer to Zarrouk's medium (Figure3). Therefore, in the future, the cultivation of MA was carried out on this AS. Experiments on the cultivation of MA were carried out in flasks with a volume of 100 to 500 ml on the rocking chairs under constant illumination with an intensity of $25 \pm 3 \mu\text{E} / (\text{m}^2 \times \text{s})$ in 3 replications in different dilutions of the AS obtained during HTL (Figure 3). It was compared with the growth of the same microalgae in nutrient media.

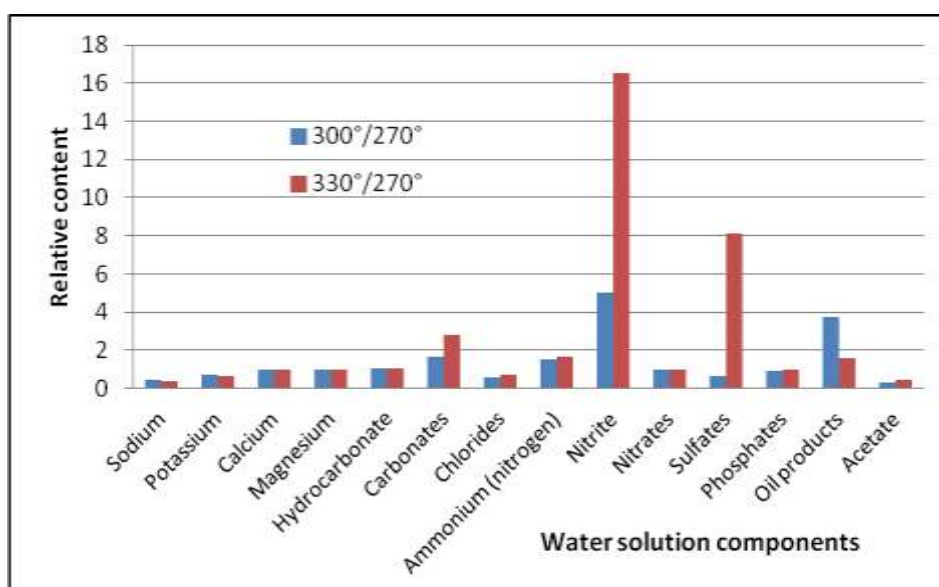

Figure 3. The relative content of the AS components in various modes of hydrothermal liquefaction (indicators obtained in the HTL process at 300 ° and 330 ° are normalized to the HTL parameters at 270°).

It was shown that the diluting of an AS with a nutrient medium or distilled water in 25, 50, 100 times completely inhibits the growth of *A. platensis* 1/02-P. Diluting of an AS with a nutrient medium in 150, 200 and 300 times provided the reduced growth of MA cells during the first 3-5 days as compared with to the nutrient media, but on the 6-7th day the growth stopped. Growth inhibition is associated with the presence of a large amount of toxic compounds in AS such as phenols, cyclic nitrogen compounds, heavy metals, ammonium ions. Growth inhibition of MA by ammonium ions was confirmed experimentally on Zarrouk's medium with excess amounts of $(\text{NH}_4)_2\text{SO}_4$. By diluting an AS in 350 times, the growth of *A. platensis* 1/02-P practically stopped between 5 and 12 days, but after 19 days the growth of some cell was intensified reaching a maximum after 26 days (Figure 4).

The toxic effect of components presented in the AS on the growth of *A. platensis* 1/02-P was eliminated when the solution was diluted with Zarrouk's nutrient medium in 350 times. However, the biomass concentration was increased only in 4 times after 25 days in the nutrient media, was reached the increase was 17 times. Analysis of the other MA strains growth (*Galdieria sulphuraria* rsemsu G-1, *Chlorella vulgaris* rsemsu Chv-20/11-Ps, *A. platensis* 1/02, *A. platensis* T), in AS after the dilution with distilled water in 500 times, showed that the most active growth under these conditions was in the case of *Galdieria*. Its growth in the first 25 days of cultivation exceeds that in the nutrient media. MA *Galdieria* and *Chlorella* was cultivated using Allen medium and Tamiya medium respectively (Allen medium: $(\text{NH}_4)_2\text{SO}_4$ – 1,32 g/l, KH_2PO_4 – 0,27 g/l, $\text{MgSO}_4 \cdot 7\text{H}_2\text{O}$ – 0,25 g/l, $\text{CaCl}_2 \cdot 6\text{H}_2\text{O}$ – 0.11 g/l, $\text{FeSO}_4 \cdot 7\text{H}_2\text{O}$ – 0.02 g/l, H_3BO_3 – 2.86 mg/l, $\text{MnCl}_2 \cdot 4\text{H}_2\text{O}$ –1.81 mg/l, $\text{ZnSO}_4 \cdot 7\text{H}_2\text{O}$ – 0.22 mg/l, MnO_3 –0.018 mg/l, NH_4VO_3 –0.023 mg/l, H_2SO_4 ~ 0.001 M per 1.0 l of distilled water.

Tamiya medium: KNO_3 – 5.0 g/l, KH_2PO_4 – 1.25 g/l, $\text{MgSO}_4 \cdot 7\text{H}_2\text{O}$ – 2.5 g/l, $\text{FeSO}_4 \cdot 7\text{H}_2\text{O}$ – 0.009 g/l, EDTA– 0.037 g/l, H_3BO_3 – 2.86 mg/l, $\text{MnCl}_2 \cdot 4\text{H}_2\text{O}$ –1.81 mg/l, $\text{ZnSO}_4 \cdot 7\text{H}_2\text{O}$ – 0.22 mg/l, MnO_3 –0.018 mg/l, NH_4VO_3 –0.023 mg/l per 1.0 l of distilled water). This result confirms the ability of *Galdieria* to mixotrophy. *Chlorella* had a steady growth also. However, it was still lower than in the nutrient media. *Arthrospira* did not show the growth mainly due to its greater sensitivity to toxic compounds and the impossibility of growth in the absence of bicarbonate ions (Figure 5).

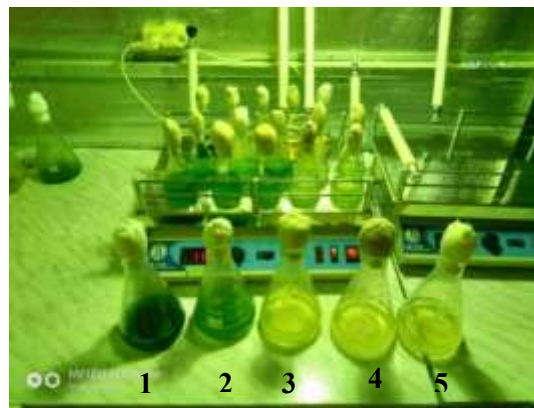

Figure 4. Cultivation of microalgae various types in HTL aqueous solution and in nutrient media as a control. One can see intensive growth of MA in the control – 1 (suspension of dark green color), dilutions 350 times – 2, and the complete lack of growth at low dilutions of an aqueous solution – 3, 4, 5 (dilutions 50, 100, 150 times respectively).

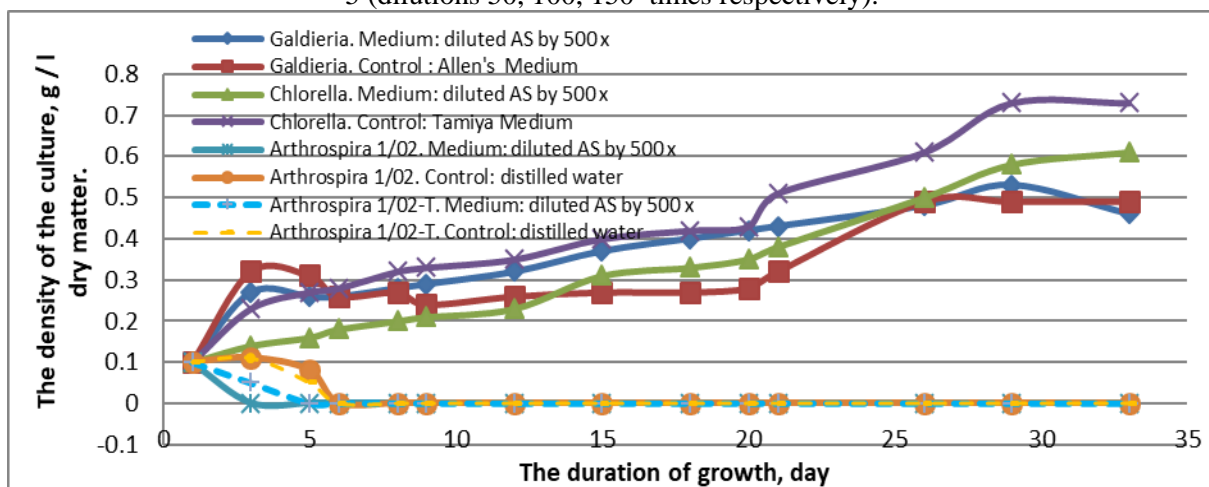

Figure 5. Dynamics of crop density when growing different strains of microalgae in AS diluted 500 times with distilled water. The control is the dynamics of density when growing the same strains on full culture media (for *Galdieria*, *Chlorella*), on distilled water (*Arthrospira 1/02*, *Arthrospira T*).

4. Conclusion

The possibility of the utilization of the nutrients from an aqueous solution obtained in HTL of *Arthrospira platensis rsemsu 1/02-P* in the process of microalgae cultivation was studied. It was found that the aqueous solution contains a large amount of nutrients, which are necessary for the MA cultivation, as well as trace elements (58 compounds were identified). The content of the nutrients in this AS is orders of magnitude higher than the standard nutrient media required for the MA cultivation. However, an AS is characterized by a toxic effect on microalgae, and growth inhibition is associated with the presence of a large number of toxic compounds (phenols, cyclic nitrogen compounds, heavy metals, ammonium ions). Intensive dilution of AS is necessary to prevent the toxic

effect of growth inhibitors. This was done by systematically varying the AS dilution, using a mixture of water and standard nutrient medium or only distilled water. Microalgae strains were experimentally selected that could grow for a long time (more than a month) on a 500-fold diluted AS after HTL – *Galdieria sulphuraria* rsemsu G-1, *Chlorella vulgaris* rsemsu Chv-20/11-Ps from the collection of Renewable Source Energy Laboratory at LMSU. All the strains are capable of mixotrophic growth, while the production of biomass may be higher than under phototrophic growth. This result was obtained when different strains of microalgae were growing in HTL AS diluted with distilled water 500 times. In this case, the productivity of the *Galdieria* strain from 7 to 25 days of cultivation in an AS exceeded the productivity in the standard Allen's nutrient medium.

References

- [1] Chernova N, Kiseleva S and Popel' O 2014 *Thermal Eng.* **61**(6) 399–405
- [2] Borowitzka M and Moheimani N 2013 *Mitig Adapt Strateg Glob Chang* **18** 13–
- [3] Chernova N, Kiseleva S, Vlaskin M and Rafikova Y 2017 *MATEC Web Conf.* **112** 10010
- [4] Skjanes K, Rebours C and Lindblad P. 2013 *Crit Rev Biotechnol* **33** 172–215
- [5] Chernova N and Kiseleva S 2017 *Int. J. of Hydrogen Energy* **42**(5) 2861-7
- [6] Vlaskin M, Chernova N, Kiseleva S, Popel' O and Zhuk A 2017 *Thermal Eng.* **64**(9) 627-36
- [7] Jena U, Das K C and Kastner J R 2011 *Biores. Technol.* **102**(10) 6221-9
- [8] Leng L, Li J, Wen Z and Zhou W 2018 *Biores. Technol.* **256** 529–42
- [9] Alba L G, Torri C, Fabbri D, Kersten S R A and Brilman D W F 2013 *Chem. Eng. J.* **228** 214–23
- [10] Biller P, Madsen R B, Klemmer M, Becker J, Iversen B B and Glasius M 2016 *Biores. Technol.* **220** 190-9
- [11] Zhou Y, Schideman L, Yu G and Zhang Y 2013 *Energ. & Environm. Sc.* **6**(12) 3765-79
- [12] Bagnoud-Velasquez M, Schmid-Staiger U, Peng G, Vogel F and Ludwig C 2015 *Alg. Res.* **8** 76-82
- [13] Dawson R, Elliott D, Elliott W and Jones K 1986 *Data for Biochemical Research* (Oxford: Oxford Science Publications)
- [14] Folch J, Lees M and Stanley G 1957 *J. Biol. Chem.* **226**(1) 497–509
- [15] Dubois M, Gilles K, Hamilton J, Rebers P and Smith F 1956 *Anal. Chem.* **28**(3) 350–6